

Tubular Handles

Tube Aluminum / Stainless Steel, Handle Legs Plastic

SPECIFICATION

Handle tube

Wall thickness 1,5 mm

- Aluminum
 - Powder coated
 - Black, RAL 9005, textured finish **SW**
 - Handle legs / Covers, black, matte finish
 - Anodized, natural color **EL**
 - Handle legs / Covers, black, matte finish
 - Anodized, natural color **ELG**
 - Handle legs / Covers, light gray, matte finish
- Stainless steel AISI 304
 - Ground, matte shiny finish **NG**
 - Handle legs / Covers, black, matte finish

Handle legs

Plastic, Polyamide (PA)

- Glass fiber reinforced
- Operating temperature up to 100 °C
- Threaded bushing steel, zinc plated

Covers

Plastic, thermoplastic elastomer (TPE)

Fastening set

- Socket cap screws ISO 4762
 - Steel, zinc plated
 - Black passivated for SW / EL / NG
 - Blue passivated for ELG
- Hex nuts ISO 4032-M8
 - Steel, zinc plated, blue passivated
- Washers DIN 125
 - Steel, zinc plated, blue passivated



INFORMATION

Owing to their large range of variants and their classic design, tubular handles GN 666.1 are the perfect choice for many applications.

The mounting screws included, allow the installation from the back or the operator's side. Tubular handles GN 666.1 and GN 666 (see page) of identical length are also suitable for double mounting, e.g. for sliding doors.

TECHNICAL INFORMATION

- Load Rating Information (see page A35)
- Plastic Characteristics (see page A2)
- Stainless Steel Characteristics (see page A26)

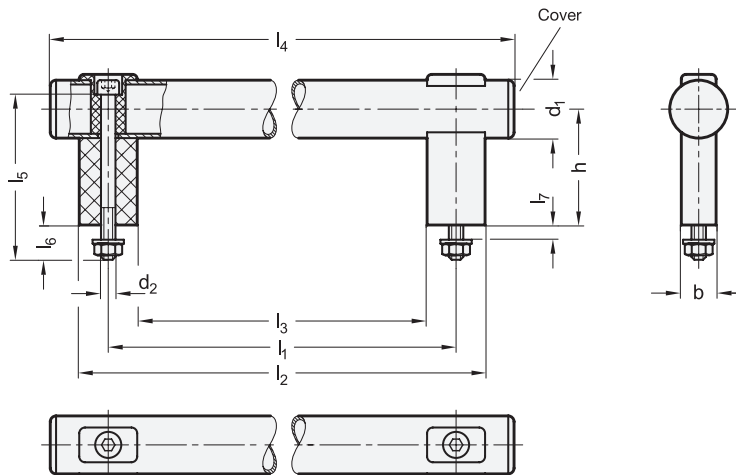

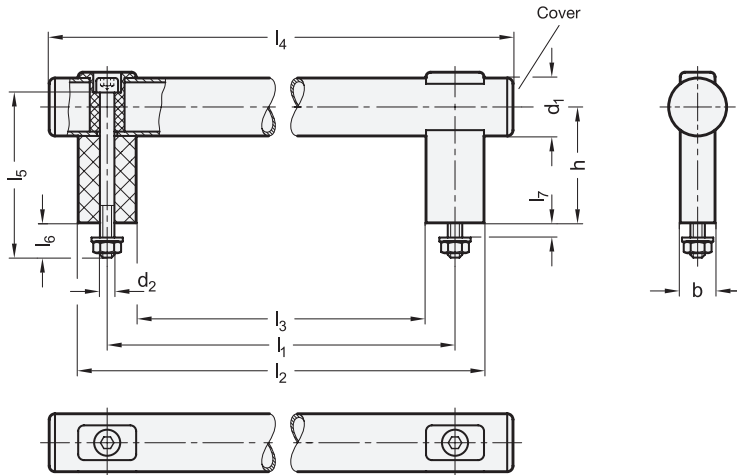

GN 666.1-SW

Description	d1	l1 ±0.5	b	d2	h	l2	l3	l4	l5	l6	l7 max.	⚖
GN 666.1-30-200-SW	30	200	18	M 8	60	230	170	265	85	17	8.5	250
GN 666.1-30-250-SW	30	250	18	M 8	60	280	220	315	85	17	8.5	280
GN 666.1-30-300-SW	30	300	18	M 8	60	330	270	365	85	17	8.5	284
GN 666.1-30-400-SW	30	400	18	M 8	60	430	370	465	85	17	8.5	360
GN 666.1-30-500-SW	30	500	18	M 8	60	530	470	565	85	17	8.5	370
GN 666.1-30-600-SW	30	600	18	M 8	60	630	570	665	85	17	8.5	394

GN 666.1-EL

Description	d1	l1 ±0.5	b	d2	h	l2	l3	l4	l5	l6	l7 max.	⚖
GN 666.1-30-200-EL	30	200	18	M 8	60	230	170	265	85	17	8.5	250
GN 666.1-30-250-EL	30	250	18	M 8	60	280	220	315	85	17	8.5	280
GN 666.1-30-300-EL	30	300	18	M 8	60	330	270	365	85	17	8.5	284
GN 666.1-30-400-EL	30	400	18	M 8	60	430	370	465	85	17	8.5	360
GN 666.1-30-500-EL	30	500	18	M 8	60	530	470	565	85	17	8.5	370
GN 666.1-30-600-EL	30	600	18	M 8	60	630	570	665	85	17	8.5	394

GN 666.1-ELG

Description	d1	l1 ±0.5	b	d2	h	l2	l3	l4	l5	l6	l7 max.	⚖
GN 666.1-30-200-ELG	30	200	18	M 8	60	230	170	265	85	17	8.5	250
GN 666.1-30-250-ELG	30	250	18	M 8	60	280	220	315	85	17	8.5	280
GN 666.1-30-300-ELG	30	300	18	M 8	60	330	270	365	85	17	8.5	284
GN 666.1-30-400-ELG	30	400	18	M 8	60	430	370	465	85	17	8.5	360
GN 666.1-30-500-ELG	30	500	18	M 8	60	530	470	565	85	17	8.5	370
GN 666.1-30-600-ELG	30	600	18	M 8	60	630	570	665	85	17	8.5	394

GN 666.1-NG

STAINLESS STEEL

Description	d1	l1 ±0.5	b	d2	h	l2	l3	l4	l5	l6	l7 max.	⚖
GN 666.1-30-200-NG	30	200	18	M 8	60	230	170	265	85	17	8.5	399
GN 666.1-30-250-NG	30	250	18	M 8	60	280	220	315	85	17	8.5	450
GN 666.1-30-300-NG	30	300	18	M 8	60	330	270	365	85	17	8.5	508
GN 666.1-30-400-NG	30	400	18	M 8	60	430	370	465	85	17	8.5	600
GN 666.1-30-500-NG	30	500	18	M 8	60	530	470	565	85	17	8.5	725
GN 666.1-30-600-NG	30	600	18	M 8	60	630	570	665	85	17	8.5	809

